

Bio 2SB

Scanjet tank cleaning equipment



KEY FEATURES

- + Rotating spray
- + 360° cleaning pattern
- + Ideal for small tanks
- + Low pressure
- + Low use of cleaning medium

The Scanjet Bio 2SB is a new type of Rotary Spray Head (RSH) tank cleaning device. Compared with conventional static devices, the Bio 2SB is very efficient, saving water and chemicals while improving cleaning effectiveness. The Bio 2SB employs a unique fluid bearing rotary mechanism, with a service life two to three times that of traditional ball bearing rotary devices.

The choice of either a clip-on (pin), weld-on or threaded connection means the Bio 2SB is always easy to install, whether building a new CIP tank cleaning system or upgrading an existing one based on ordinary static or rotary spray devices.

With 360° impact coverage, self-cleaning and self-draining features, the Bio 2SB design follows EHEDG and GMP guidelines, and can be supplied with EN10204-2.1, 2.2 or 3.1 material and FDA 21CFR compliance certificates. The Bio 2SB-XXX-A clip-on and weld-on versions have attained 3A certification under sanitary standard 78-01. Surface finish roughness supplied as standard is $R_a = 0.8 \mu\text{m}$ (30 μ inch); other surfaces are available upon request.

The Bio 2SB can be used in conjunction with the Scanjet WASHTRAC sensor to monitor and verify its operation and performance.

The Bio 2SB is the first choice for anyone looking for the most advanced Rotary Spray Head tank cleaning device available.

The Scanjet Bio 2SB Rotary Spray Head can be used in a wide range of applications, including:

- + Mixing vessels
- + Blending tanks
- + Beverage tanks
- + Dairy tanks
- + Yeast tanks
- + Reactors
- + IBCs



Technical performance

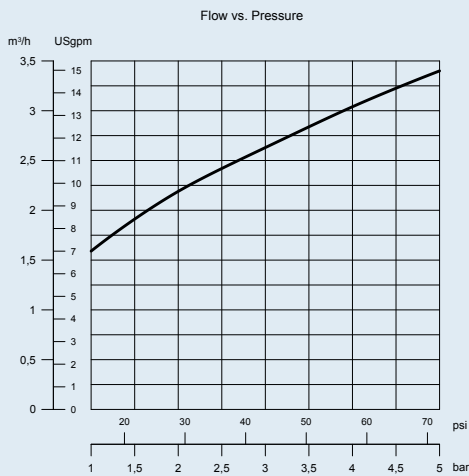

* Clip-on models have approx. 0,5 m³/h higher flow rate

Pressure/Flow

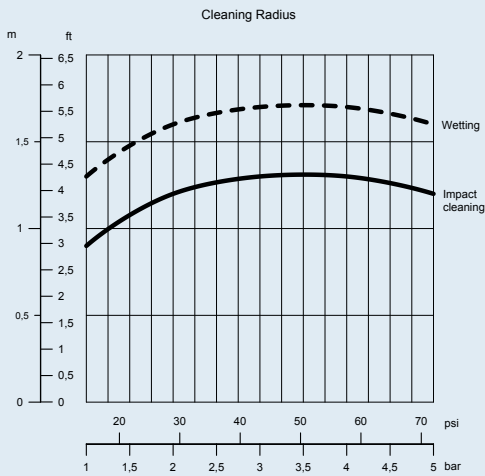

Cleaning radius

Dimensions

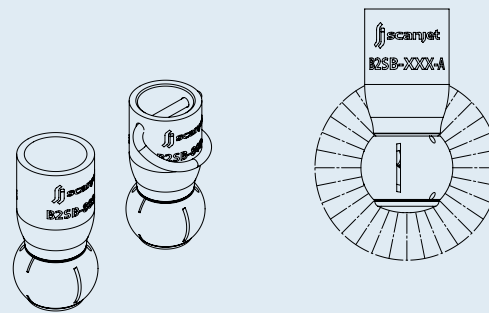
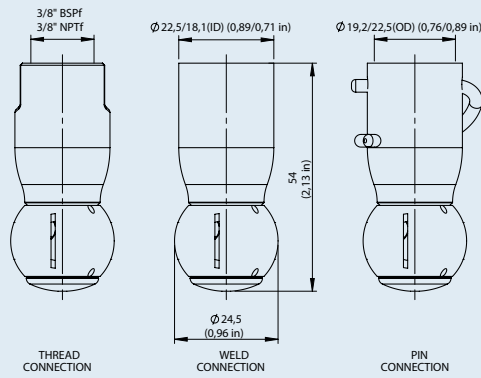

Specifications

Flow*	1.6-3.4 m ³ /h (7-15 USgpm)
Inlet pressure	1.5 bar (14-72 psi)
Max pressure	5 bar (72 psi)
Recommended pressure	3 bar (43 psi)
Max working temperature	95°C (200°F)
Max ambient temperature	150°C (300°F)
Weight	53-73 g (1.9-2.6 oz)
Connections	3/8" NPT or BSP Weld connection Pin connection
Material	EN1.4404/PEEK 450G
Lubrication	Self lubricated by media



Scanjet Systems AB
 P.O. Box 9316
 SE-400 97 Göteborg Sweden
 Phone + 46 31 3387530
 Fax + 46 31 3387540
 E-mail sales@scanjetsystems.com
 Web www.scanjetsystems.com